



P-750 XSTOL[®]

PERFORM WHERE OTHERS CAN'T

PACIFIC AEROSPACE

www.xstol.com

P-750 XSTOL®

XSTOL = The ability of an aircraft to take-off and land in less than 800 ft while carrying a load greater than its own weight.

Proven in some of the most challenging operating environments, the FAA Single Pilot IFR approved P-750 XSTOL sets the benchmark for single engine turbo-prop aircraft. In STOL operations it is unsurpassed in its ability to access more strips, more often, with more payload; even in hot and high conditions.

With its unmatched reliability and low maintenance costs, the P-750 XSTOL is an aircraft that maximises profitability. It enables you to realise a profit on routes that were previously marginal due to accessibility and/or payload constraints.

The P-750 XSTOL is a very versatile platform and is delivered from the factory in a variety of configurations including: passenger, utility, skydive, medivac, aerial survey, surveillance and crop dusting/spraying. From the mountains of Nepal to the desert of Sudan and the jungles of Papua New Guinea the P-750 XSTOL is making a difference in people's lives and earning its operators more profit than any other aircraft type in those roles.

WEIGHTS

Basic Empty Weight	3,300 lb	1,497 kg
Max. Take-Off Weight	7,500 lb	3,402 kg
Max. Landing Weight	7,125 lb	3,232 kg
Max. Useful Load	4,200 lb	1,905 kg

PERFORMANCE (Normal Conditions, 7,500 lbs)

Take-Off Ground Roll	721 ft	220 m
Take-Off Distance to 50 ft	1,196 ft	364 m
Landing Ground Roll *	543 ft	166 m
Landing Distance from 50 ft*	950 ft	289 m
Rate of Climb (MTOW)	1,067 ft	325 m/min
Max. Cruise Speed	164 kt	303 kph
Stall Speed (MTOW) Flaps Up (Vs)	58 kt	107 kph
Max. Range at 15,000 ft	582 nm	1,079 km

* Reverse Thrust selected at touchdown

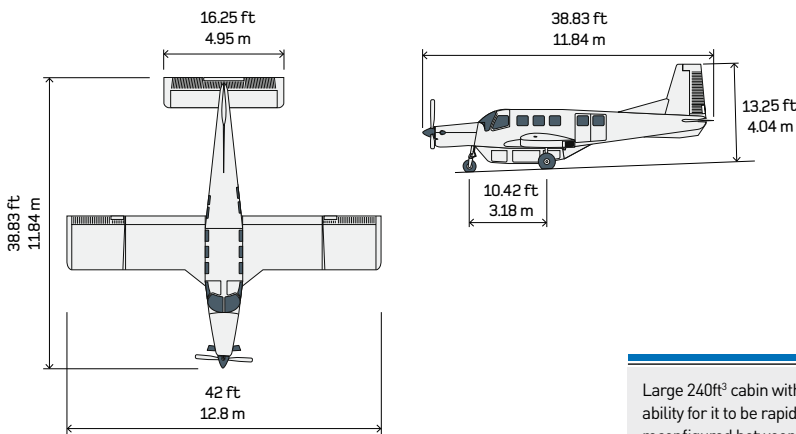

FAA single pilot IFR approved cockpit with control stick standard on both sides and easy access "gull wing" crew doors.

Constant speed, full feathering and reversible prop for short-field performance.

Large air intake is optimised for rapid climb, and provides RAM air and thrust recovery even at low forward speeds. An effective inertia separation system for FOD protection is incorporated in the inlet.

High strength fixed landing gear with oleo pneumatic shock strut allowing for customisation of the cylinder pressure to the conditions. Optional large tyre installation with a 46% increase in the tyre footprint for soft field operations.

Well proven and globally supported Pratt & Whitney Canada PT6A-34 Turbine Engine producing 750shp.

High volume (70ft³, 1,000lb) single compartment (removable divider nets) cargo pod with a hinged rear loading ramp able to take full lengths of plywood, roofing iron and other over sized items.

Low wing for superior low speed stability, final approach visibility and ease of access for pre-flight checks, refuelling and maintenance.

Rear compartment for the stowage of the eight removable passenger seats.

Large double doors for rapid loading and unloading of passengers and freight.

Thick chord wing for high lift.

Large powerful single slotted flaps spanning the centre wing providing a 58kts stall speed.

PACIFIC AEROSPACE

Pacific Aerospace Ltd, Private Bag 3027, Hamilton 3240, New Zealand
 TEL +64 7 843 6144 FAX +64 7 843 6134 aircraft@xstol.com www.xstol.com